

# A2

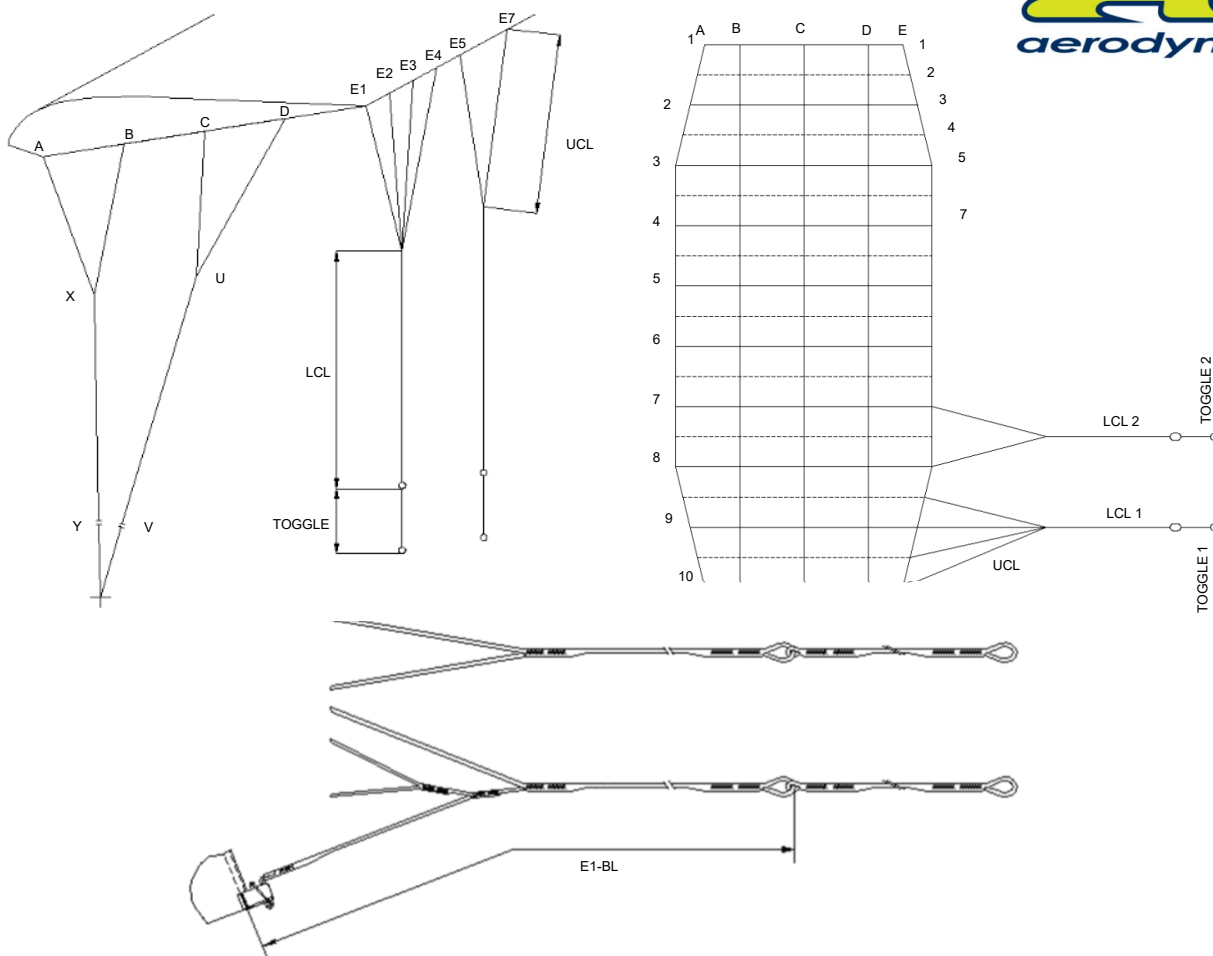

Canopy	310	330	350	370	389
AXY1	4450	4606	4773	4970	5102
A1-B1	85	91	93	96	100
A1-C1	260	263	273	283	291
A1-D1	475	489	506	524	541
AXY2	4530	4688	4858	5031	5194
A2-B2	80	83	86	89	88
A2-C2	260	270	280	290	296
A2-D2	525	545	565	585	599
AXY3	4450	4604	4771	4940	5101
A3-B3	60	63	65	67	69
A3-C3	270	277	287	297	305
A3-D3	560	578	599	620	639
LCL1	2470	2554	2647	2741	2830
LCL2	3010	3114	3227	3342	3490
TOGGLE 1	630	650	674	698	742
TOGGLE 2	630	650	674	698	742
E1-BL	4630	4786	4954	5125	5296
E2-BL	4750	4914	5082	5253	5434
E3-BL	4750	4913	5081	5252	5433
E4-BL	4810	4971	5151	5334	5507
E5-BL	4930	5102	5287	5475	5690
E7-BL	4930	5102	5287	5475	5690

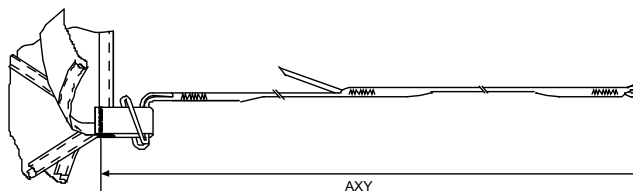

ENSURE LOOPS ARE HELD EVENLY AND SECURELY. EACH LINE TO BE LOADED TO 4.5KG DURING MEASUREMENT.

AXY : MEASURE FROM END OF SUSPENSION LINE LOOP TO BANTACK ON SUSPENSION LINE ATTACHMENT TAB.

E-BL : MEASURE FROM BOTTOM OF BRAKE LOOP TO CENTER OF BANTACK ON UCL ATTACHMENT TAB.

All dimensions in mm

VERSION 1.2

# A2

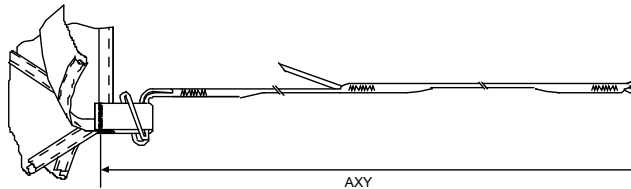
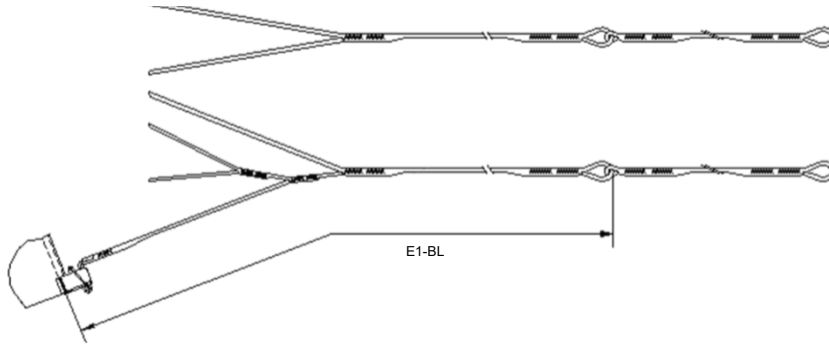
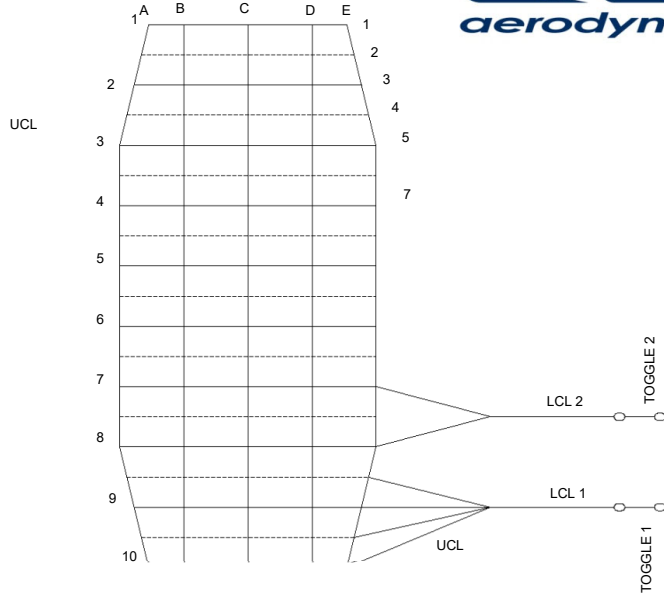
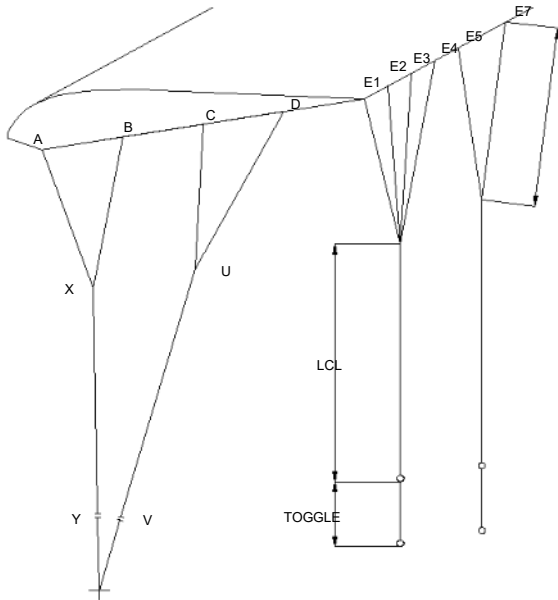

Canopy	310	330	350	370	389
AXY1	175 1/4	181 1/4	188	195 3/4	200 3/4
A1-B1	3 1/4	3 1/2	3 3/4	3 3/4	4
A1-C1	10 1/4	10 1/4	10 3/4	11 1/4	11 1/2
A1-D1	18 3/4	19 1/4	20	20 3/4	21 1/4
AXY2	178 1/4	184 2/4	191 1/4	198	204 1/2
A2-B2	3 1/4	3 1/4	3 1/2	3 1/2	3 1/2
A2-C2	10 1/4	10 3/4	11	11 1/2	11 3/4
A2-D2	20 3/4	21 1/2	22 1/4	23	23 1/2
AXY3	175 1/4	181 1/4	187 3/4	194 2/4	200 3/4
A3-B3	2 1/4	2 1/2	2 1/2	2 3/4	2 3/4
A3-C3	10 3/4	11	11 1/4	11 3/4	12
A3-D3	22	22 3/4	23 1/2	24 1/2	25 1/4
LCL1	97 1/4	100 1/2	104 1/4	108	111 1/2
LCL2	118 1/2	122 1/2	127	131 1/2	137 1/2
TOGGLE 1	24 3/4	25 1/2	26 1/2	27 1/2	29 1/4
TOGGLE 2	24 3/4	25 1/2	26 1/2	27 1/2	29 1/4
E1-BL	182 1/4	188 1/2	195	201 3/4	208 1/2
E2-BL	187	193 1/2	200	206 3/4	214
E3-BL	187	193 1/2	200	206 3/4	214
E4-BL	189 1/4	195 3/4	202 3/4	210	216 3/4
E5-BL	194	200 3/4	208 1/4	215 1/2	224
E7-BL	194	200 3/4	208 1/4	215 1/2	224

ENSURE LOOPS ARE HELD EVENLY AND SECURELY. EACH LINE TO BE LOADED TO 4.5KG DURING MEASUREMENT.

AXY : MEASURE FROM END OF SUSPENSION LINE LOOP TO BARTACK ON SUSPENSION LINE ATTACHMENT TAB.

E-BL : MEASURE FROM BOTTOM OF BRAKE LOOP TO CENTER OF BARTACK ON UCL ATTACHMENT TAB.

All dimensions in inches

VERSION 1.2