

A2

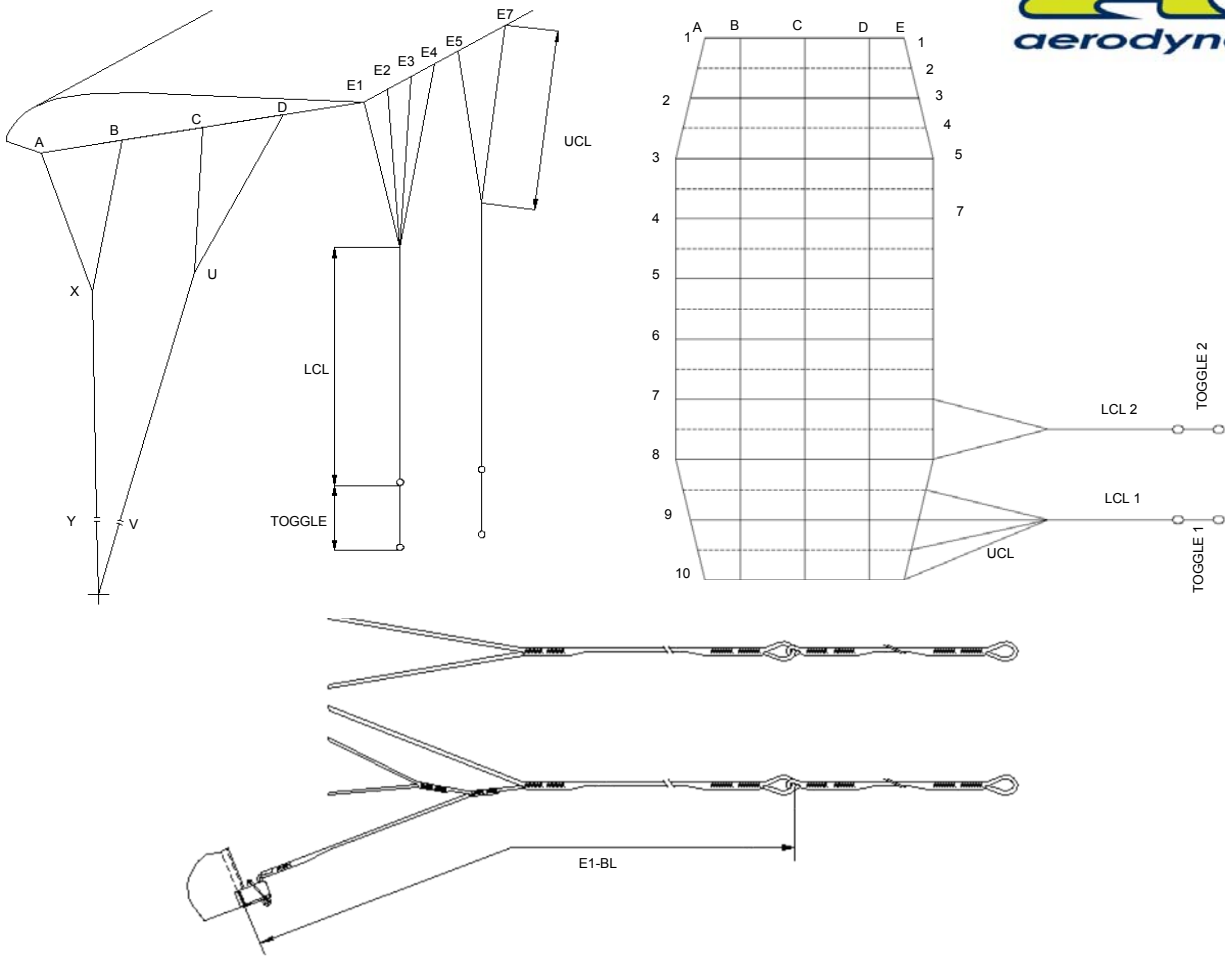

Canopy	330	350	370	389
AXY1	181 1/4	188	195 3/4	200 3/4
A1-B1	3 2/4	3 3/4	3 3/4	4
A1-C1	10 1/4	10 3/4	11 1/4	11 2/4
A1-D1	19 1/4	20	20 3/4	21 1/4
AXY2	184 2/4	191 1/4	198	204 2/4
A2-B2	3 1/4	3 2/4	3 2/4	3 2/4
A2-C2	10 3/4	11	11 2/4	11 3/4
A2-D2	21 2/4	22 1/4	23	23 2/4
AXY3	181 1/4	187 3/4	194 2/4	200 3/4
A3-B3	2 2/4	2 2/4	2 3/4	2 3/4
A3-C3	11	11 1/4	11 3/4	12
A3-D3	22 3/4	23 2/4	24 2/4	25 1/4
LCL1	100 2/4	104 1/4	108	111 2/4
LCL2	122 2/4	127	131 2/4	137 2/4
TOGGLE 1	25 2/4	26 2/4	27 2/4	29 1/4
TOGGLE 2	25 2/4	26 2/4	27 2/4	29 1/4
E1-BL	188 2/4	195	201 3/4	208 2/4
E2-BL	193 2/4	200	206 3/4	214
E3-BL	193 2/4	200	206 3/4	214
E4-BL	195 3/4	202 3/4	210	216 3/4
E5-BL	200 3/4	208 1/4	215 2/4	224
E7-BL	200 3/4	208 1/4	215 2/4	224

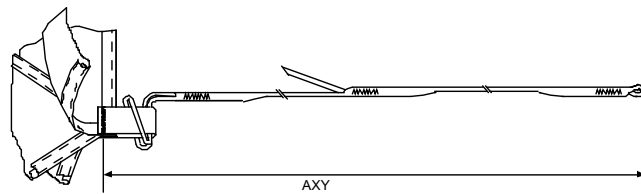

ENSURE LOOPS ARE HELD EVENLY AND SECURELY. EACH LINE TO BE LOADED TO 4.5KG DURING MEASUREMENT.

AXY : MEASURE FROM END OF SUSPENSION LINE LOOP TO BARTACK ON SUSPENSION LINE ATTACHMENT TAB.

E-BL : MEASURE FROM BOTTOM OF BRAKE LOOP TO CENTER OF BARTACK ON UCL ATTACHMENT TAB.

All dimensions in Inches

VERSION 1.1